

Fulflo® FH Filter Vessels

- 304 Stainless Steel
- 316L Stainless Steel

Multi-Cartridge Filter Vessel Series

FH 7 and 12 Cartridge Filter Vessels

The FH 7 and 12 cartridge filter vessels are a lightweight, **economical** industrial and commercial design suitable for a wide variety of filtration applications. The 100% stainless steel and bead blasted finish provides superior corrosion resistance and an excellent appearance. The closure V-retainer coupling features a unique filtration industry exclusive design that allows both the clamp and cover to remain attached to the vessel body during cartridge change-out. This hinged clamp and cover design makes cartridge change-out quick and easy. PED compliance consult Parker.

Applications

- Potable Water
- Process Water
- Edible Oils
- Coatings
- Lubricants
- Coolants
- Cutting Oils
- Solvents



Features and Benefits

- Hinged cover and V-retainer coupling for fast, easy cartridge changeout.
- V-retainer coupling remains attached to the filter body to minimize loose parts during cartridge change-out.
- Maximum design pressure is 150 psig (10.3 bar) at 250°F (126°C) for use in a wide range of operating conditions.
- 100% stainless steel for corrosion resistance.
- Stainless steel clamp for corrosion free operation.
- Dual purpose cartridge seat for use with Double Open End and 2-222 O-ring cartridges.
- 316 Stainless steel cartridge seats and tri-fold guides for long term use.
- Standard Buna-N O-ring with optional Viton® and EPR for wide range of applications.
- Vent, clean drain and dirty drain connections for safe, clean operation.
- Three connection styles to match a variety of piping systems.
- Three types of finishes available for a wide range of applications.

Process Filtration Division

WARNING! FAILURE OR IMPROPER SELECTION OR IMPROPER USE OF THE PRODUCTS AND/OR SYSTEMS DESCRIBED HEREIN OR RELATED ITEMS CAN CAUSE DEATH, PERSONAL INJURY AND PROPERTY DAMAGE. This document and other information from Parker Hannifin Corporation, its subsidiaries and authorised distributors provide product and/or system options for further investigation by users having technical expertise. It is important that you analyse all aspects of your application and review the information concerning the product or system in the current product catalogue. Due to the variety of operating conditions and applications for these products or systems, the user, through its own analysis and testing, is solely responsible for making the final selection for the products and systems and assuring that all performance, safety and warning requirements of the application are met. The products described herein, including without limitation, product features, specifications, designs, availability and pricing, are subject to change by Parker Hannifin Corporation and its subsidiaries at any time without notice.



Multi-Cartridge Filter Vessel Series

"B" DIM. APPLIES TO ALL INLET/OUTLET TYPES

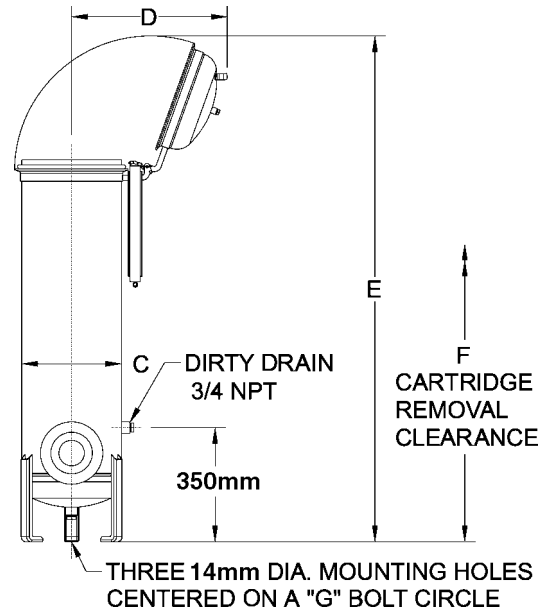
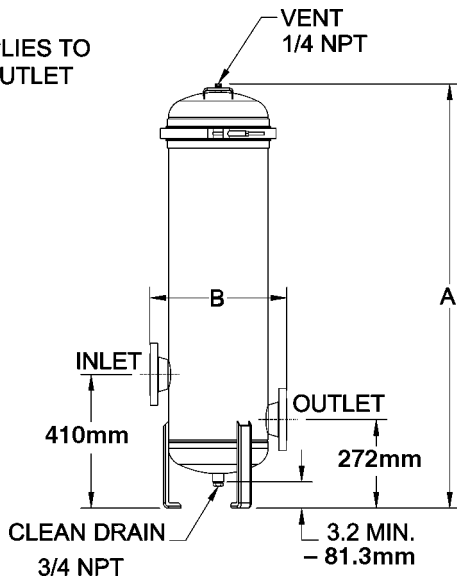

Dimensions

Model	Cartridge Qty.	Cartridge in mm	Typical flow+ l/min	A		B		C		D		E		F		G		Weight Kg
				in	mm	in	mm	in	mm	in	mm	in	mm	in	mm	in	mm	
FH*7D2T**	(7) 20"	508	370	40.5	1030	12.5	320	10.0	254	18	457	48.9	1240	55	1400	8.24	223	31
FH*7D2F**	(7) 20"	508	370	40.5	1030	14.5	370	10.0	254	18	457	48.9	1240	55	1400	8.24	223	35
FH*7D2C**	(7) 20"	508	370	40.5	1030	13.0	330	10.0	254	18	457	48.9	1240	55	1400	8.24	223	31
FH*7T2T**	(7) 30"	762	556	50.5	1290	12.5	320	10.0	254	18	457	58.9	1500	75	1910	8.24	223	35
FH*7T2F**	(7) 30"	762	556	50.5	1290	14.5	370	10.0	254	18	457	58.9	1500	75	1910	8.24	223	40
FH*7T2C**	(7) 30"	762	556	50.5	1290	13.0	330	10.0	254	18	457	58.9	1500	75	1910	8.24	223	35
FH*7Q2T**	(7) 40"	1016	742	60.6	1540	12.5	320	10.0	254	18	457	68.9	1750	95	2410	8.24	223	40
FH*7Q2F**	(7) 40"	1016	742	60.6	1540	14.5	370	10.0	254	18	457	68.9	1750	95	2410	8.24	223	45
FH*7Q2C**	(7) 40"	1016	742	60.6	1540	13.0	330	10.0	254	18	457	68.9	1750	95	2410	8.24	223	40
FH*12T3F**	(12) 30"	762	954	51.1	1300	16.5	420	12.0	305	19	483	60.9	1550	75	1910	10.24	273	52
FH*12T3C**	(12) 40"	1016	954	51.1	1300	14.75	380	12.0	305	19	483	60.9	1550	75	1910	10.24	273	44
FH*12Q3F**	(12) 30"	762	1272	61.2	1560	16.5	420	12.0	305	19	483	70.9	1800	95	2410	10.24	273	58
FH*12Q3C**	(12) 40"	1016	1272	61.2	1560	14.75	380	12.0	305	19	483	70.9	1800	95	2410	10.24	273	50

+Actual flow rate is dependent on fluid viscosity, micron rating, contaminant, and media type. Consult media flow charts for each application.

FH	G	7	2	3	F	N	P
Design Series	Material of Construction	Number of Columns	Cartridge Length	Inlet/Outlet Size	Inlet/Outlet Type	Cover Gasket	Finish
	G = 304 SS S = 316/L SS	7 12	D = 508mm T = 767mm Q = 1016mm	2 = 2 in 3 = 3 in	F = ANSI 150 lb. Flange T = FNPT C = Sanitary	N = Buna-n V = Viton® E = EPR	B = Glass Bead Blast P = Passivate E = Electro Polish

Process Filtration Division